

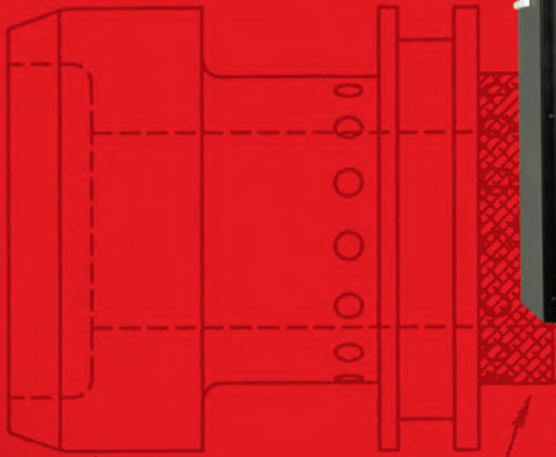

ABOVE AND BEYOND HONING

VSS[®] SERIES 2

PRECISION SINGLE STROKE[®]
HONING SYSTEM



SUNNEN'S VSS-2 IS THE SOLUTION FOR MEDIUM-TO-HIGH-RUN

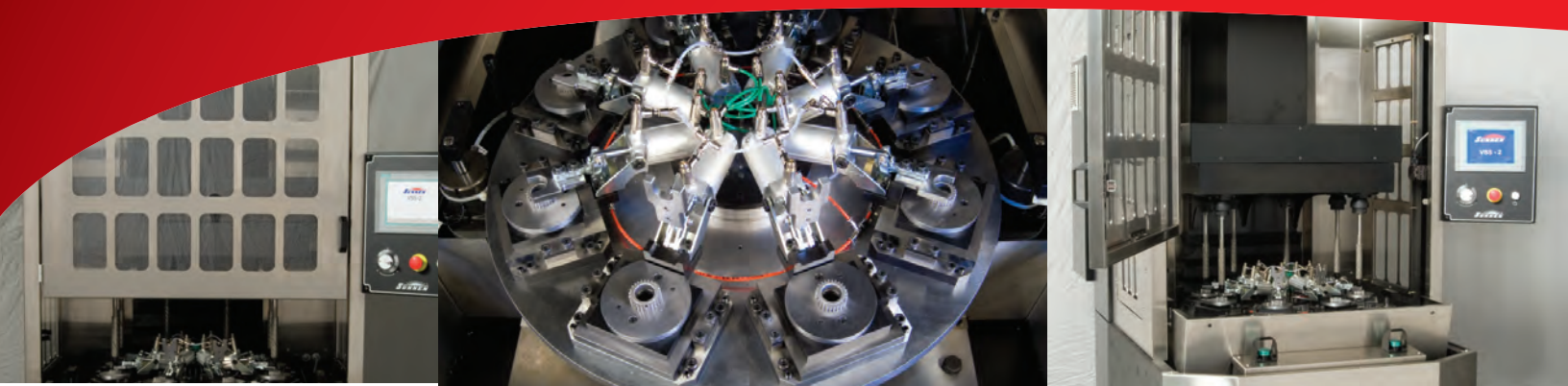

Sunnen has long led the industry in creating complete solutions for precision honing with both single-pass and conventional honing systems. The introduction of the new VSS-2 Single Stroke[®] Honing system is no exception, as it delivers industry-leading performance in a value-priced, customizable package.

The VSS-2 is a compact, rugged system that delivers precise bore size, geometry, and surface finish control. In addition, it is economical to own and run, easy to operate, and simple to maintain.

The VSS-2 incorporates an advanced spindle design and flexible, easy-to-use controls to provide a new level of precision for single-pass honing. Simple set-up screens and an

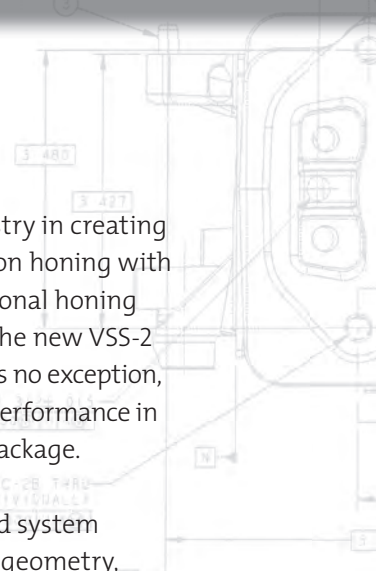

PRECISION HONING



easy-to-use operator interface panel help simplify machine set-ups and operation, which reduces the time required to train new operators. Set-ups can be easily entered and stored for future production runs and repeat orders. That means more up time for the system and more finished parts at the end of the day.

For precision, versatility, economy, and ease of use, the VSS-2 is the perfect choice. It handles most diameters up to 50 mm (2.0 inches). For larger diameters, contact your Sunnen Sales and Application Engineer or authorized Sunnen International Distributor.

Among single-pass machines, the VSS-2 has no equal, but contrary to what others in the industry may contend, not all parts applications are good candidates for single-pass processing.

Your Sunnen Technical Specialist will work with you to determine the best solution for your needs – it's all part of the added value you get with Sunnen. Whether you need a Single Stroke® or conventional honing system, we have the expertise and product range to create the right solution for you.



KEY FEATURES PUT THE VSS-2 SINGLE STROKE® HONING A SYSTEM IN A CLASS BY ITSELF.

MACHINE FEATURES

CE compliant stainless steel guarding, state-of-the-art safety system includes door interlock, safety PLC and sage limited setup mode -- all standard.

Powerful, 7.5 kW (10 Hp) spindle motor for optimum performance and precision.

Vertical positions are set quickly and precisely with a servo motor/ball screw feed control system.

Rapid table index and column traverse times increase productivity.

Steel tooling plate provides a solid foundation for parts fixturing.

Dual palm buttons for operator safety.

Standard LED work area lighting

Heavy-duty, solid cast polymer composite base provides maximum rigidity for top performance.



SOFTWARE FEATURES

Large 225 mm (9 in) color touch screen
Siemens PLC control system coupled
with servo column feed provides
optimum process control with ease
of set-up.

Spindle speed and column speed can
be varied as needed.

Such operations as pecking, short-
stroke and dwell can be easily added
to the set-up.

Programmable positions allow
complex motion profiles.

Automation interface provides
seamless automation integration:
robotic interface for loading and
unloading; pneumatic interface for
easy fixture integration.

Multiple setups can be entered and
saved for future production runs of
the same components.

State-of-the-art electronics with
touch screens and hand wheel
controls reduce setup time and
increase machine "up time."

ADDITIONAL FEATURES

- Multiple languages are screen selectable.
- Vertical, compact design provides more useable floor space.
- Work area is easily accessible from the front, left, and right sides.
- Uses Sunnen's plated diamond Single Stroke® Honing tools for precise bore size, geometry, and surface finish.
- Double index table options are available for increased production.
- Custom fixtures and automated loading/unloading can be designed for your specific application.

VSS-2 FLOOR PLAN LAYOUT

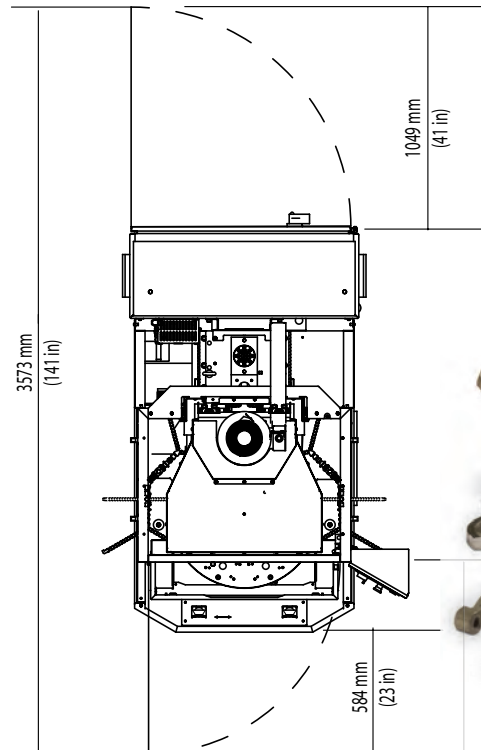

THE PERFECT CHOICE FOR SMALL BORES

The VSS-2 is perfect for small-bore, 50 mm (2.0 inches) medium- to high-production runs. Applications include:

- Hydraulic valves and valve bodies
- Parking pawls
- Most gears
- Powdered metal components
- Ceramic components
- Sprockets
- Rocker arms

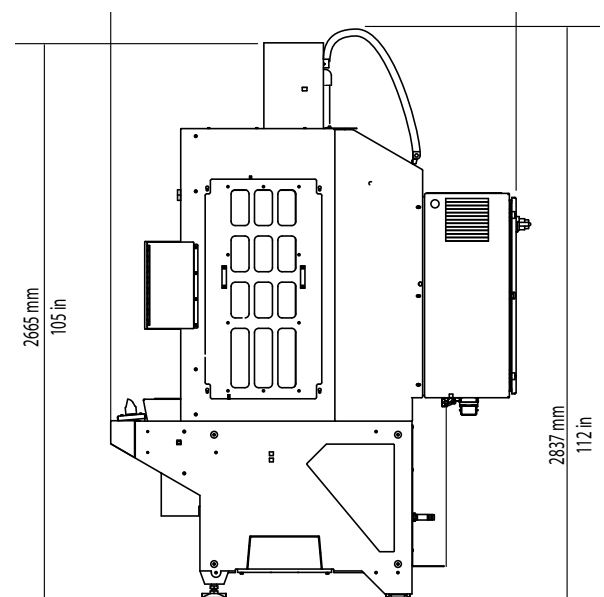
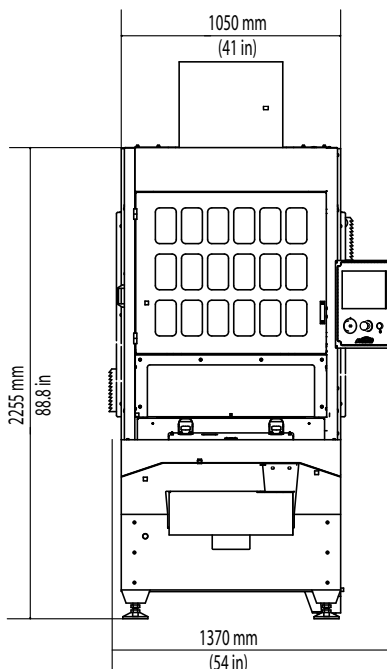

CUSTOMIZE THE VSS-2 TO YOUR EXACT REQUIREMENTS

Since 1924, Sunnen has defined the state of the art in the industry, and our current generation of high precision honing systems represents the very finest solutions available anywhere in the world. Sunnen systems are reliable, durable, and flexible and are designed to deliver the precision our customers have grown to expect.

From design to delivery, you have the Sunnen commitment to service and quality. Our technical experts will work with you to create a complete solution to fit your exact requirements, including the machine model, number of spindles, style of tooling, fixture design, abrasives selection, automation and gaging packages, and any other platform customization you may require.

After your system is built, we'll set up a live run-off demonstration at our facility. Once it meets all specifications, we'll commission

VSS-2 AUTOMATION OPTIONS

Our automation options are designed to increase the operational efficiency of your precision honing system while significantly reducing labor costs. Sunnen automation solutions can keep your system running 24 hours a day,

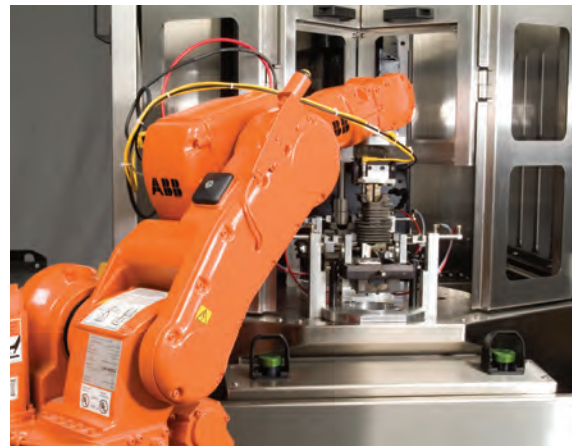

A TWO-AXIS OR MULTI-AXIS SERVO ROBOT CAN BE INTEGRATED INTO A SUNNEN MODULAR HONING SYSTEM.

"We can customize and automate the VSS-2 to meet your specialized application requirements. Just contact your Sunnen representative for a free needs analysis to get the design process started."

VSS-2 TOOLING, HONING OILS AND COOLANTS

SPECIFICATIONS:

SPINDLE SPEED:

100 to 2250 RPM

SPINDLE POWER:

7.5 kW (10 Hp)

CARRIAGE TRAVEL:

724 mm (28.5 inches)

CARRIAGE SPEED RANGE:

up to 105 mm/sec (250 IPM)

DIAMETER RANGE*:

3.9 to 50 mm (.149 to 2.0 inches)

** CONTINGENT UPON APPLICATION*

FLOOR SPACE (MACHINE ONLY):

WIDTH X LENGTH

1370 x 3753 mm (90 x 60 inches)

WEIGHT:

Approximately 2,087 kg (4,600 lb)

ELECTRICAL SYSTEM:

- 400/460 V, 50/60 Hz, 3ph
- (Optional 230 V to 460 V transformer is available)

ORDERING INFORMATION:

Machine configurations
(specify at the time of order):

- VSS-246 (4 station rotary index table with 6 spindle column)
- VSS-264 (6 station rotary index table with 4 spindle column)
- VSS-284 (8 station rotary index table with 4 spindle column)
- VSS-286 (8 station rotary index table with 6 spindle column)

OPTIONAL EQUIPMENT:

- Adjustable spindle nose
- Floating tool holder
- Pneumatic air regulator and filter for fixturing
- 12-port rotary union (includes filter/regulator)
- 16-port rotary union (includes filter/regulator)
- Coolant sump pump
- Automatic lubrication system
- Machine status stack light
- Tool adjustment indicator
- SVF-15 Coolant Systems (pictured below)



SINGLE STROKE® HONING TOOLS ENSURE PRECISE BORE SIZE, GEOMETRY, AND SURFACE FINISH

Plated diamond Single Stroke® Honing tools go through the bore only once, removing a predetermined amount of stock, progressively enlarging the bore. After the final pass, the bore is to size, straight and round, with the desired surface texture.

A-TYPE TOOLS:

STANDARD SIZES:
5.9 – 26.4 mm
(.23 – 1.04 inches)*

CUSTOM SIZES:
3.78 – 100 mm
(.149 – 4.0 inches)*

HPH-TYPE TOOLS:

For high performance applications, Sunnen's High-Production Helix, plated diamond Single Stroke® Honing tools provide maximum accuracy and fast cycle time.

STANDARD SIZES:
6.35 – 25.0 mm
(.25 – .99 inches)*

CUSTOM SIZES:
3.78 – 100 mm
(.149 – 4.0 inches)*

**FOR DIAMETER SIZES ABOVE OR BELOW THE STANDARD RANGE, OR SPECIALLY DESIGNED TOOLS, CONTACT YOUR SUNNEN SALES & APPLICATION ENGINEER.*

SUNNEN PREMIUM HONING OILS AND COOLANTS

Sunnen's premium honing oils and coolants provide extreme lubricity for higher honing pressure and harder abrasives, delivering faster, lower cost-per-part and ultimately more





A LEGACY OF EXCELLENCE SINCE 1924.

WORLDWIDE

Our global manufacturing, distribution, and sales and service network allows us to deliver quality Sunnen solutions worldwide.

And our state-of-the-art Technical Services Centers allow our technical experts to develop innovative solutions to customer application challenges. The Centers also provide answers for customer questions and training for Sunnen representatives around the world.

SUNNEN PRODUCTS COMPANY
WORLD HEADQUARTERS
St. Louis, MO – USA
Phone 1.314.781.2100
Fax 1.314.781.2268
Toll Free 1.800.325.3670
Email sunnen@sunnen.com
www.sunnen.com



AUSTRIA - SUNNEN AUSTRIA GMBH **HOHENEMS**

Phone +43 5576 74194
Fax +43 5576 74196
Email sales@sunnen.eu
www.sunnen.at

BELGIUM - SUNNEN BENELUX BVBA **KONTICH**

Phone +32 38 80 2800
Fax +32 38 44 3901
Email info@sunnen.be
www.sunnen.be

BRAZIL - SUNNEN DO BRASIL LTDA. **SÃO PAULO**

Phone +55 11 4177-3824
Fax +55 11 4362-3083
Email sunnen@sunnen.com.br
www.sunnen.com.br

CHINA - SHANGHAI SUNNEN **MECHANICAL Co. LTD.**

SHANGHAI
Phone +86 21 5813 3990
FAX +86 21 5813 2299
Email shsunnen@sunnensh.com
www.sunnensh.com

CZECH REPUBLIC - SUNNEN S.R.O. **STRAKONICE**

Phone +420 383 376 317
Fax +420 383 376 316
Email sunnen@sunnen.cz
www.sunnen.cz

FRANCE - SUNNEN SAS **SACLAY**

Phone +33 169 30 00 00
Fax +33 169 30 11 11
Email info@sunnen.fr
www.sunnen.fr

INDIA - SUNNEN INDIA PVT. LTD. **MUMBAI**

Phone +91 223 913 6055
Fax +91 223 913 6056
Email sales@sunnen.in
www.sunnen.in

ITALY - SUNNEN ITALIA S.R.L. **ARESE**

Phone +39 02 383 417 1
Fax +39 02 383 417 50
Email sunnen@sunnenitalia.com
www.sunnenitalia.com

POLAND - SUNNEN POLSKA Sp. z o.o. **WARZAWA**

Phone +48 22 814 34 29
Fax +48 22 814 34 28
Email sunnen@sunnen.pl
www.sunnen.pl

RUSSIA - SUNNEN RUS LLC **MOSCOW –**

Phone +7 495 258 43 43
Fax +7 495 258 91 75
Email sunnen@sunnen-russia.ru
www.sunnen.ru

SWITZERLAND - SUNNEN AG **ENNETAACH**

Phone +41 71 649 33 33
Fax +41 71 649 33 34
Email sales@sunnen.eu
www.sunnen.eu

UK - SUNNEN PRODUCTS LTD. **HEMPSTEAD HERTS**

Phone +44 1442 39 39 39
Fax +44 1442 39 12 12
Email hemel@sunnen.co.uk
www.sunnen.co.uk

Sunnen reserves the right to change or revise specifications and product design in connection with any feature of our products contained herein. Such changes do not entitle the buyer to corresponding changes, improvements, additions, or replacements for equipment, supplies or accessories previously sold. Information contained herein is considered to be accurate based on available information at the time of printing. Should any discrepancy of information arise, Sunnen recommends that user verify the discrepancy with Sunnen before proceeding.